

NOVUS

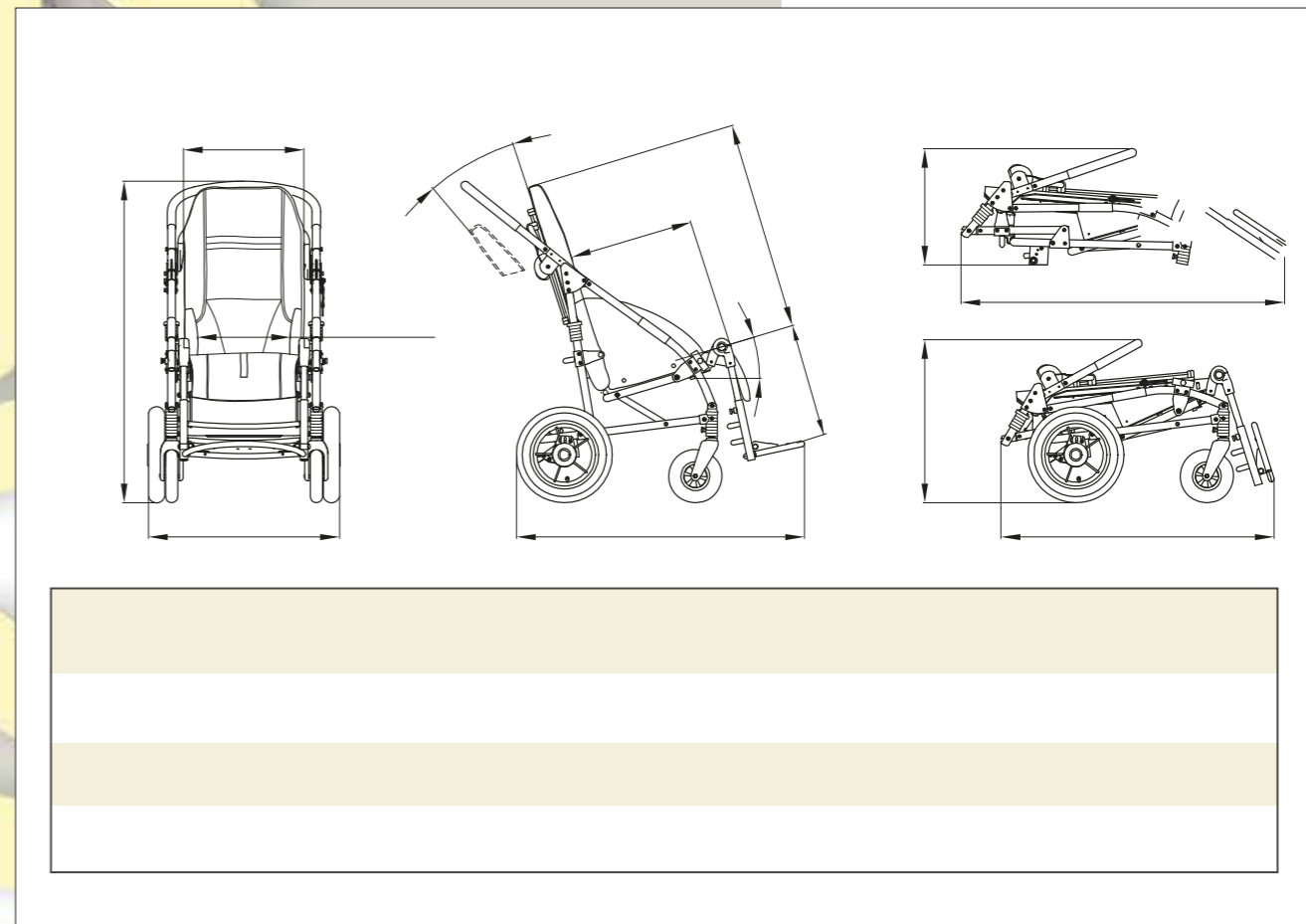

 design and quality
MADE IN ITALY since 1980

ORMESA

Technical features and functions

accessories



852 HEADREST with Parietal Supports. It is adjustable in height and width



863 HEADREST with Occipital-parietal Supports. It is adjustable in height, in width, in tilt, forwards and backwards



853 VEST HARNESS



903 FIVE POINT VEST HARNESS



906 FIVE POINT HARNESS



838 PADDED SIDE SUPPORTS



868 SIDE WRAPPABLE and FLEXIBLE SUPPORTS for the trunk. Height and width adjustable



828 CHEST BELT



894 45° BELT FOR THE PELVIS

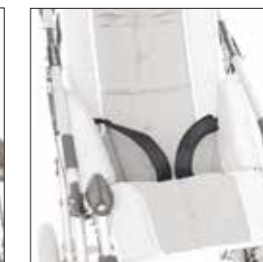

817 INGUINAL STRAPS

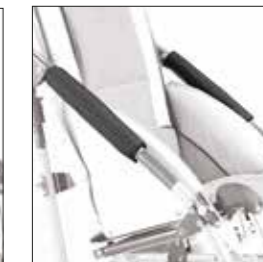

844 SIDE PROTECTING COVERS



834 ABDUCTION BLOCK



834 ADJUSTABLE ABDUCTION BLOCK



824 TRANSPARENT TRAY



839 FRONT HANDLE



827 FOOTSTRAPS



892 FOOT PLATE PADDED COVERING



812 WHEEL DIRECTION LOCK



818 THERMAL COVER



819 CANOPY

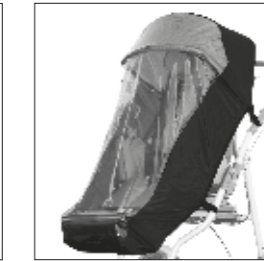

825 RAIN COVER to be fixed to the 819 canopy



854 PARASOL matching with the upholstery



905 HAND BRAKE (rear view)



922 BOTTLE HOLDER



858 MESH BASKET



911 VENT TRAY, for carrying medical equipment (rear view)



891 SET OF 4 TIE DOWN HOOKS for the forward-facing transport of the pushchair in a motor vehicle (private vans/cars, buses..)

- Aluminium FOLDABLE FRAME (fig.1) painted with non-toxic epoxy powders
- Padded, ergonomic and removable UPHOLSTERY. It is fixed to the seat thanks to press-studs. Fireproof, recyclable, maximum resistance to rubbing. Oeko-Tex Classe 1 Certificate the highest reachable class for textile products intended for infants and children, for all fabrics that are in direct contact with the skin, to guarantee quality and safety for health. Colours durable and highly resistant to sweat, light, dry cleaning and washing machine. It was designed to make the change of position of the side supports easier, and to fix or unfix the accessories without causing any trouble to the child while he is seated. It grows up with the frame



- SEAT, adjustable in width and depth
- RIGID BACKREST, adjustable in height and in tilt
- REMOVABLE WHEELS snap-off (fig. 2), sliding on ball bearings:
 - front 17,5-cm. (7"), swivel, puncture-proof
 - rear 30-cm. (12"), pneumatic. Puncture-proof rubber or request
- INDEPENDENT DRUM BRAKES, without any dangerous projections



(fig.1)



(fig.2)